

High-Sensitivity Streak Camera Applicable to Time-Resolved Spectroscopy*

Shigeto MIURA, Tsuneaki GOTO, Yasuhiko SYONO
and Yasuaki NAKAGAWA

The Research Institute for Iron, Steel and Other Metals

(Received August 31, 1979)

Synopsis

A high-sensitivity streak camera has been designed and manufactured using a photoelectric tube with deflecting plates and a microchannel plate which serves as both a streak device and an image intensifier. Characteristics of the complete equipments are as follows: (1) an image on the film is 10.2 times as large as an image on the photoelectric surface, (2) effective area of the film is 45 mm in diameter, (3) resolution on the film is 2.5 lp/mm, (4) writing speed on the film is 0.2~20 mm/ μ s, 5-stage variable, (5) sensitivity is controlled by the microchannel plate voltage, and (6) a spectroscope is combined to take time-resolved spectrographs, 1 mm on the film corresponding to 0.9 nm of the wavelength.

I. Introduction

A high speed streak camera is very useful to solid state researches under pulsed ultrahigh magnetic fields above 100 T^(1,2) and/or dynamic ultrahigh pressures up to 100 GPa.⁽³⁾ We have manufactured a rotating-mirror streak camera with the highest writing speed of 10 mm/ μ s,⁽²⁾ and obtained satisfactory results⁽²⁻⁵⁾ by using this camera. Nevertheless, the light sensitivity of this camera is somewhat insufficient. In order to increase the sensitivity, use has been made of an image intensifier tube based on the multiplication of photo-electrons. We have used the image intensifier tube made by Hamamatsu TV Co., Ltd., which has deflecting plates so as to serve as a streak-image tube. Therefore, our new apparatus is utilized not only as an image intensifier attached to the rotating-mirror streak camera but also as an independent image-converter streak camera with reasonable sensitivity.

* The **1702th** report of the Research Institute for Iron, Steel and Other Metals.

- (1) Y. Nakagawa, Y. Syono, T. Goto and J. Nakai, *Sci. Rep. RITU*, **A25** (1974), 1.
- (2) J. Nakai, T. Goto, Y. Syono and Y. Nakagawa, *Sci. Rep. RITU*, **A25** (1975), 174.
- (3) T. Goto, Y. Syono, J. Nakai and Y. Nakagawa, *Sci. Rep. RITU*, **A25** (1975), 186.
- (4) Y. Syono, T. Goto, J. Nakai and Y. Nakagawa, *Proc. 4th Intern. Conf. on High Pressure (Kyoto, 1974)*, 466.
- (5) T. Goto, Y. Syono, J. Nakai and Y. Nakagawa, *Solid State Commun.*, **18** (1976), 1607.

II. Image intensifier tube

Figure 1 shows a sectional view of the image intensifier tube. This is similar to that used for Hamamatsu TV's streak camera, HTV-C979X⁽⁶⁾, which has the

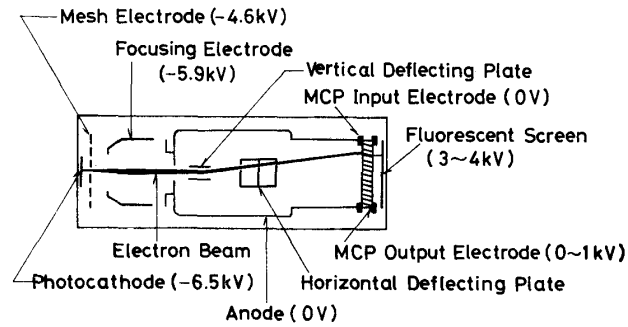

Fig. 1. Schematic sectional view of image intensifier tube.

writing speed of 1.5~15 mm/ns, much higher than that of our apparatus. The outside size of the tube is about 70 mm in diameter and 140 mm in length. The tube is consisting of ten electrodes and the operating voltage is shown in Fig. 1. When the tube is used for a simple image intensifier, the deflecting plates are employed only for a controller of the position of an image. When the tube is used for a streak camera, the time-dependent deflection voltage is applied to the vertical deflecting plates. The sensitivity of the vertical deflection on the screen is about 19 mm/kV.

The S-20 photocathode deposited onto a thin metal substrate has the size of 6 mm×8 mm, and Al-metal backed P-11 fluorescent screen has a diameter of 15 mm. The ratio of the image on the photocathode to the image on the fluorescent screen is 1:3.4; accordingly, the photocathode has the effective area of 4.4 mm in

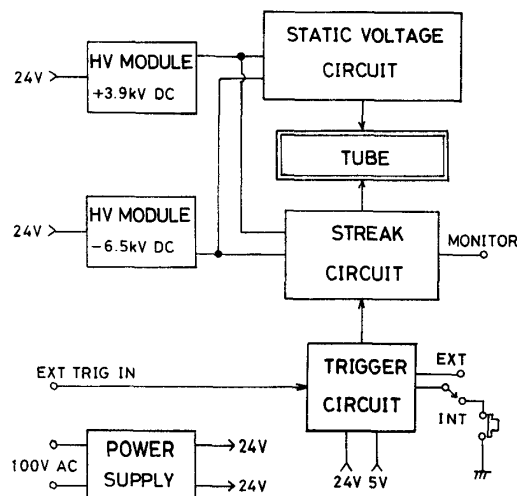
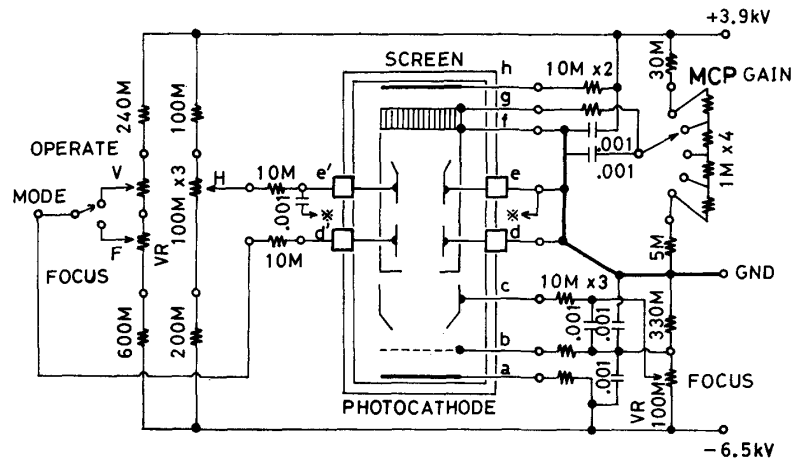

Fig. 2. Block-diagram of streak camera.

(6) Y. Tsuchiya, E. Inuzuka and Y. Suzuki, *Proc. 13th International Congress of High Speed Photography and Photonics (Tokyo, 1978)*, 517.

diameter. The microchannel plate (MCP) has a channel diameter of $14 \mu\text{m}$. Its electron amplification factor expressed by the current gain is 1.7×10^3 .

A block diagram of the equipment is shown in Fig. 2, and detailed circuits are shown in Fig. 3: (a) circuit for applying static voltage to the tube, (b) circuit for applying linearly rising voltage to the deflecting plates, (c) circuit for triggering, (d) circuit of power supply. When the equipment is used simply for the image intensifier, the circuits (b) and (c) are unnecessary. When the equipment is used for the streak camera, the sweeping speed of the streak image on the fluorescent screen can be variable from $0.07 \text{ mm}/\mu\text{s}$ to $7 \text{ mm}/\mu\text{s}$ by changing the emitter resistance R in Fig. 3(b).



- a : Photocathode
- b : Mesh Electrode
- c : Focusing Electrode
- d, d' } Vertical Deflecting Plate
- e, e' } Horizontal Deflecting Plate
- f : MCP Input Electrode
- g : MCP Output Electrode
- h : Fluorescent Screen

(a) Static voltage circuit.

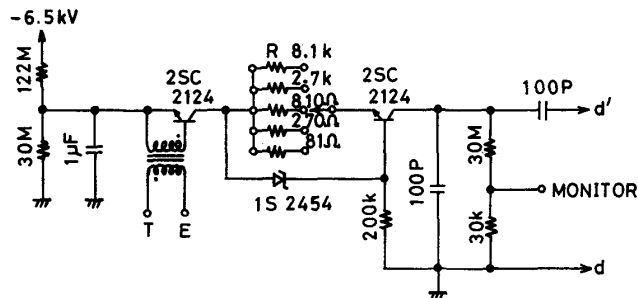

(b) Streak circuit.

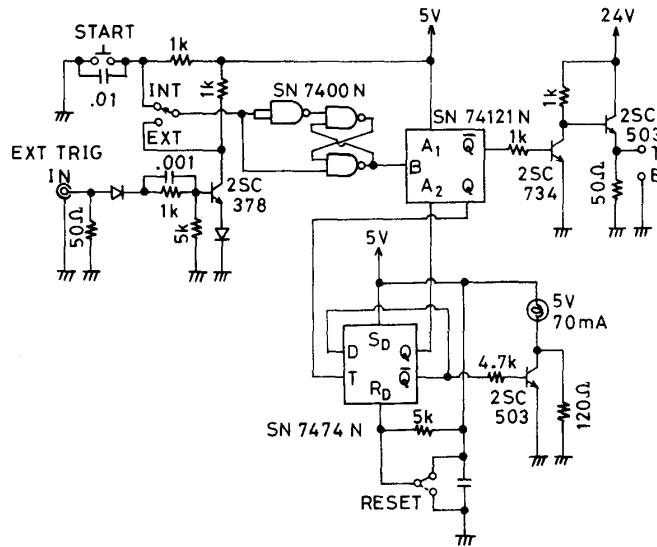

(c) Trigger circuit.

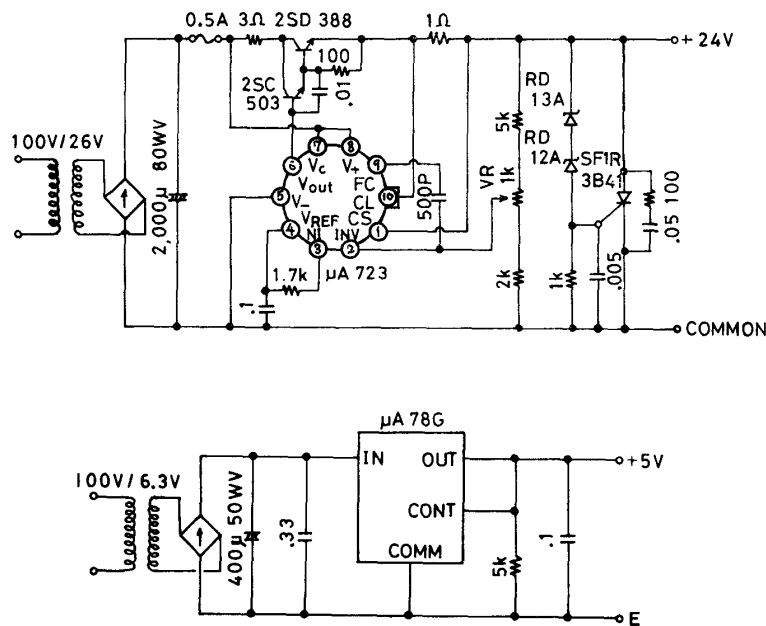

(d) Power supply.

Fig. 3. Main circuits for streak tube.

III. Optical system of the streak camera

The optical system of the apparatus, shown in Fig. 4, is divided into the following two subsystems: one is to focus an objective image on the optical plane of the image intensifier tube using a camera and a relay lens I and the other is to take a photograph of the picture on the fluorescent screen of the tube using a relay lens II. The two relay lenses have the same characteristics.

The image formed on the fluorescent screen is transferred to a photographic film mounted on a cassette made by Mamiya Optical Instr. Co., Ltd.. This

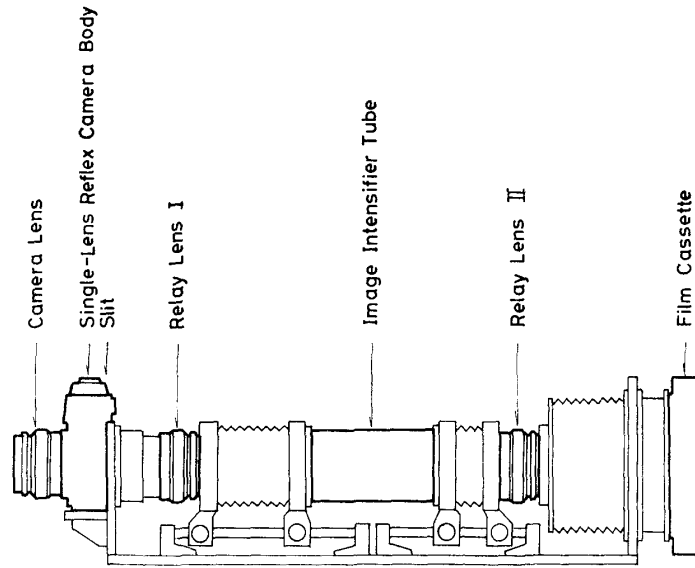

Fig. 4. Schematic diagram of optical arrangement.

cassette with a focusing screen holder permits to use both Polaroid films ($83 \times 108 \text{ mm}^2$) and cut films ($56 \times 83 \text{ mm}^2$). The image of 15 mm on the fluorescent screen is magnified to the image of 45 mm on the film.

In order to cover a variable size of the object placed at a variable distance, a single-lens reflex camera body (Nikon F2) is used, which has the wide selection of lenses. The finder and the focal plane shutter of the camera body can be used in the usual manner. By means of some processing of a back cover of the camera, a slit can be inserted into the focusing plane. The slit image is focused on the photocathode plane by the relay lens I (EL Nikkor F2.8, $f=50 \text{ mm}$). Thus the image of the object is focused on the photocathode plane by the two lenses, the camera lens and the relay lens I, which are necessary for inserting the slit. Now we discuss the brightness and uniformity of the picture under the combined system of two lenses. Figure 5(a) shows that the focusing image illustrated by an arrow has uniform brightness, if the aperture l_2 of relay lens I is so large that

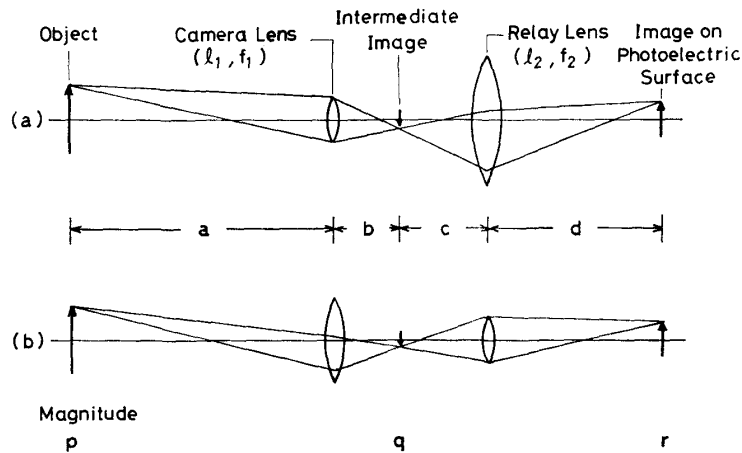

Fig. 5. Brightness of image by using two lenses.

$$l_2 \geq \frac{c}{b} l_1 + \left(1 + \frac{c}{b}\right) q \quad (1)$$

is satisfied, where b , c and q are defined in Fig. 5. On the other hand, under the condition

$$l_2 \leq \frac{c}{b} l_1 - \left(1 + \frac{c}{b}\right) q, \quad (2)$$

as shown in Fig. 5 (b), the image with uniform brightness can also be obtained. If only the brightness of the image along an optical axis is concerned, the most reasonable condition is as follows:

$$l_2 = \frac{c}{b} l_1. \quad (3)$$

In this case, however, the off-axis image becomes dark.

In this apparatus, the effective diameter r of photocathode is 4.4 mm, the focal length f_2 of relay lens I is 50 mm, the aperture l_2 of relay lens I is 17.9 mm and the ratio d/c is 2; accordingly d is 150 mm, c is 75 mm and q is 2.2 mm. A suitable camera lens is used according to the condition of experiments. Here, the following two test conditions are examined.

If Micro-Nikkor lens (F3.5, $f=55$ mm, $l_1=55/3.5=15.7$ mm) is used for the purpose of such a close shot that the distance a between the object and the camera is 330 mm, b is found to be 66 mm. So the relation (3) is nearly fulfilled, and the uniformity of the brightness of the image is not guaranteed. Accordingly, the relation (2) or (1) must be satisfied by stopping down either the relay lens I above F3.9 or the camera lens above F4.8.

If the telephoto lens (F4.5, $f=300$ mm, $l_1=300/4.5=66.7$ mm) is used for a very long shot ($a \rightarrow c$), b tends to 300 mm. In this case, neither the relation (1) nor (2) is satisfied for the maximum aperture of the lenses. To obtain the uniform brightness, the relay lens I must be stopped down above F3.6 or the camera lens must be stopped down above F5.0. When the control of brightness is required, either the relay lens I or the camera lens must be stopped down. If both lenses are stopped down at the same time, the uniformity of the brightness of image may be failed.

IV. Combination of the streak camera with a spectroscope

The high speed rotating-mirror streak camera previously made by the present authors has been combined with Nikon G 250 monochromator. This has a merit to permit easy construction because the incident light and the exit light lie along a straight line, but it has a demerit of uneven resolution and non-uniform brightness of a spectrogram because it is not designed for the spectroscope but for the monochromator. In order to eliminate the demerit, our new streak camera is combined with Mizojiri SG-12D-5BS spectroscope. The exit slit has the length of 60 mm,

but it is limited to 22 mm for the present purpose. The image of the slit is directly focused on the photocathode of the intensifier tube with the relay lens I in Fig. 4, so the camera body is removed in this case.

The brightness of the image can be estimated with the relations (1) and (2) by referring to Fig. 5, where a concave mirror of the spectroscope ($f=500$ mm, $l=110$ mm) is placed instead of a camera lens. The value of b is 500 mm for $a \rightarrow \infty$, and q and r must be equal to 22 mm and 4.4 mm, respectively. If the relay lens I is the same as above-mentioned one ($f=50$ mm, $l_2=17.9$ mm), it is calculated that $d=59$ mm and $c=334$ mm. Using these values, it is clear that the relation (2) is satisfied, so the brightness is uniform. The brightness is not limited by the spectroscope but by the relay lens I. If the relay lens I with larger aperture (up to F1.6) is used, the light sensitivity of the optical system is improved without loss of uniformity of brightness.

When the streak camera is combined with a spectroscope, another optical system is needed because an image of an object is formed at an entrance slit of the spectroscope. The camera body removed from the intensifier tube in Fig. 4 can be used for this purpose. The discussion on the brightness of this system is omitted here for brevity.

V. Testing results

Figure 6 shows the photograph of the apparatus without the spectroscope. Characteristics of the apparatus are tested in the following order: (1) in using as the static image intensifier, (2) in using as the usual streak camera, and (3) in using as the streak camera for time-resolved spectroscopy.

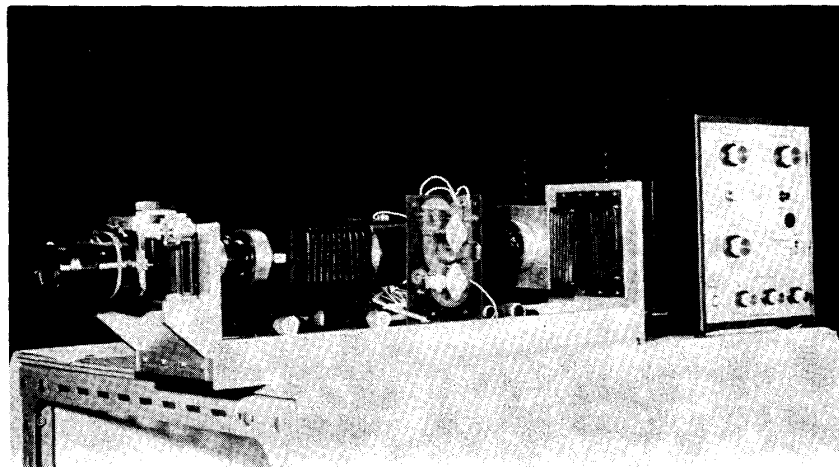

Fig. 6. A general view of streak camera.

1. *Image amplification factor, distortion and resolution*

Each of the electrode of image intensifier tube is given the standard operating voltage indicated in Fig. 1 to take a photograph of a section paper with 2 mm

squares. The distance between object and camera lens is 370 mm. The resultant photo is shown in Fig. 7. The magnifications of the camera lens, the relay lens I, the image intensifier tube and the relay lens II are 0.17, 2, 3.4 and 3, respectively, giving the total magnification of 3.5. Figures 7(a) and (b) are the photographs when the vertical deflecting plates are given the voltage of 0 V and 450 V respectively, showing a shift of 26 mm in the longitudinal direction. The deflecting sensitivity can be estimated from the shift to be about 19 mm/kV. These pictures have the spool type distortion, which becomes larger as the deflection voltage is higher. Since the distortion by the lens system can be ignored, the distortion of the image is regarded as an aberration of the electrostatic convergence of the image intensifier tube. The limiting resolutions are estimated as 25 lp/mm on the photocathode, 7.5 lp/mm on the fluorescent screen and 2.5 lp/mm on the photographic film.

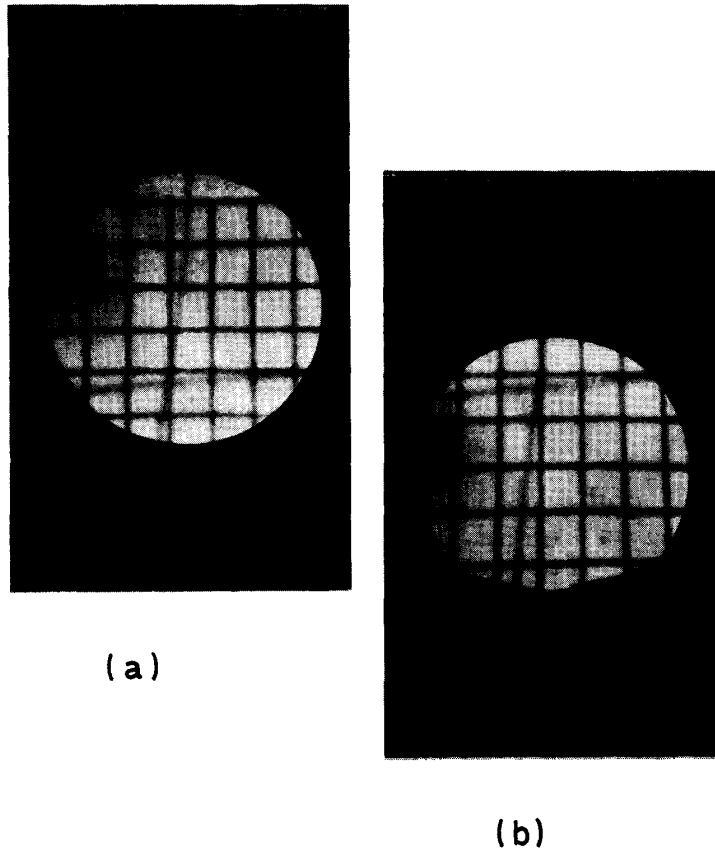

Fig. 7. Distortion of image.
(a) Deflection Voltage is 0 V. (b) Deflection Voltage is 450 V.

2. Brightness of static image

The brightness of the image is varied sensitively by the applied voltage of microchannel plate (MCP). When the continuous light with constant intensity enters the photocathode, the intensity of light emitted by the fluorescent screen is measured by a photomultiplier. The results are shown in Table 1. Where the

symbol # refers to a selected guide number of the MCP gain.

According to the maker's specifications, the maximum applied voltage of MCP is 1,000 V, but, at present, the voltage is limited up to 900 V. The photographs in Fig. 7 are obtained with a Polaroid type 107 land film, the MCP gain #2 and the exposure time of 0.25 sec.

Table 1. Microchannel plate gain versus applied voltage

#	voltage across microchannel plate (volt)	output voltage of photomultiplier tube (relative)
1	500	0.012
2	600	0.070
3	700	0.270
4	800	0.605
5	900	1.000

In order to make clear whether the present apparatus is useful for a simple image intensifier such as nightvision or not, it is desired to compare the degree of blackening of the film directly exposed to the ray from a light source with that exposed to the light emitted by the fluorescent screen when the ray from the same light source strikes on the photocathode. Nevertheless, we must consider that the latter image is magnified to the size of 10.2 times. Therefore, in the former case, the image is magnified to the size of 10.2 times by a relay lens with sufficiently large aperture and is transferred to the film. The frosted glass lighted up by an incandescent lamp is used for the light source, and the blackening of Polaroid type 107 land film is examined. The iris of the lens system is fixed and the exposure time is varied. In order to obtain the same degree of blackening the exposure time in the former case is twice as long as that in the latter case when MCP gain #5 is selected, i.e. the light gain of the image intensifier is at most 2 in magnitude.

The cause of such a small gain is a large light loss at the transfer of the image from the fluorescent screen to the film. Since a solid angle at a point on the fluorescent screen subtended by the relay lens is $2\pi \times 8.9 \times 10^{-3}$ sterad, the less than one percent light is utilized as compared with the direct coupling of the film with the fluorescent screen using fiber optics. When a Ripro-Nikkor lens (F1.0, $f=85$ mm) is used instead of a EL-Nikkor lens for the relay lens and the image is transferred without magnification, the solid angle becomes $2\pi \times 3.0 \times 10^{-2}$ sterad, so the light gain is fairly improved.

3. Characteristics as a streak tube

The image intensifier tube can be used for the streak tube when the voltage V is supplied to the vertical deflecting plates, the time derivative dV/dt of which is constant. As described in the preceding section, the sensitivity of deflection is 19 mm/kV, so the voltage must be varied by about 800 V in order to sweep the

image on the fluorescent screen with 15 mm. To give the deflection voltage, a streak circuit shown in Fig. 3(b) is utilized. This circuit is based on the principle that the voltage across a capacitor is increased in proportion to time by a constant current through a transistor. The value of dV/dt is inversely proportional to the resistance R in Fig. 3(b). As a result of the measurement, $dV/dt=35 \text{ V}/\mu\text{s}$ for $R=810 \ \Omega$. In this case, considering the deflection sensitivity and the magnification of the image, the writing speed on the film is calculated as $2.0 \text{ mm}/\mu\text{s}$. The value of R is changed in five stages, and the writing speed is varied from 0.2 to $20 \text{ mm}/\mu\text{s}$. Figure 8 shows the time dependence of the deflection voltage measured by a monitor. The linearity of the writing speed depends on not only the linearity of this trace, but also the characteristics of the static deflection and the distortion of the image.

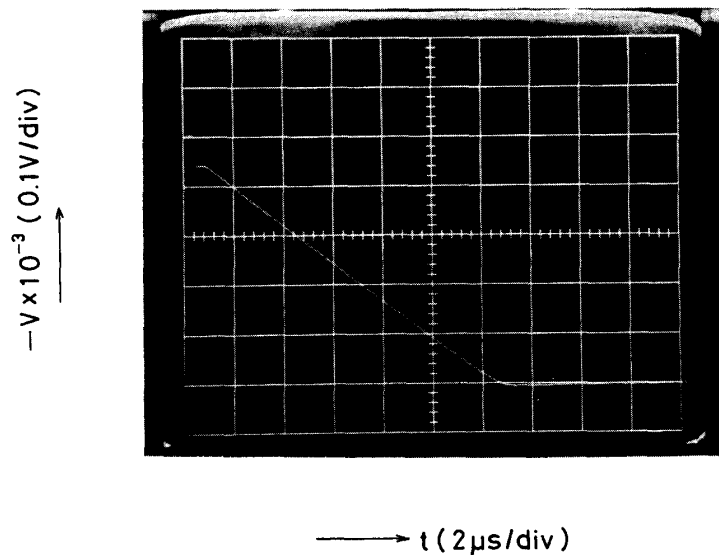

Fig. 8. Linearity of deflection voltage versus time.

The most important matter to obtain a photograph of a high speed phenomenon is the adjustment of timing. When the high-speed rotating-mirror streak camera is used, the phenomenon to be observed must be started by a command pulse from the camera, since the observable time is strictly limited. When the streak tube is used, on the other hand, any pulse from the phenomenon can be used for triggering the tube. The trigger circuit is shown in Fig. 3(c).

4. Example of streak photograph of real object

Photographs of luminosity of a xenon-filled flash lamp are taken by the optical arrangement shown in Fig. 4. The slit with $10 \mu\text{m}$ width is inserted at the place of the intermediate image between the camera lens and the relay lens I. Both irises of the relay lenses I and II are fully opened. The camera lens (Micro Nikkor) is stopped down to $F8 \sim 32$ and MCP gain is #5 or #4. The resultant photographs are shown in Fig. 9. The film is Polaroid type 107 land film. The

writing speed is $2 \text{ mm}/\mu\text{s}$. The applied deflection voltage is not 800 V but 600 V , so the image does not sweep all over the fluorescent screen. Accordingly a horizontal line appears at the lower part of the photograph. This line is a stationary image of the slit.

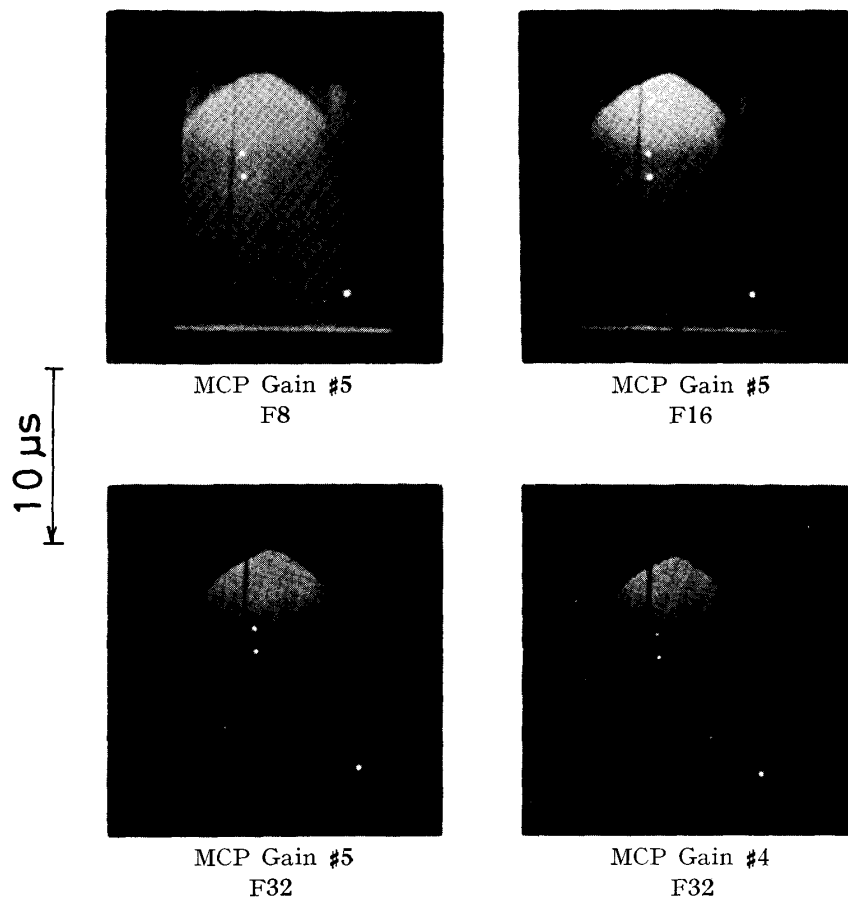

Fig. 9. Streak photograph of xenon-flash.

In order to evaluate the brightness of the streak photograph taken by this apparatus, it is compared with that taken by the rotating-mirror streak camera,⁽²⁾ under the same conditions of the slit width, the magnification factor and the writing speed. It is found that the rotating-mirror camera is brighter for the strong light while the streak tube camera is four times more sensitive for the weak light. The response of the streak tube may approach the saturation for the strong light. In spite of the use of the streak tube with the image intensifier, the sensitivity is only four times higher than that of the rotating-mirror camera. The results are below expectations. As mentioned in the previous section, the great light loss at the image transfer from the fluorescent screen to the film must be eliminated.

5. Example of streak photograph of spectral lines

A time-resolved spectrograph of xenon-filled flash lamp is taken by using the optical arrangement mentioned in IV. The length of an exit slit of the

spectroscope is 22 mm, corresponding to 45 mm on the film. The spectroscope has a diffraction grating of 1,800 lines/mm, and 1 mm on the film corresponds to the wavelength of about 0.9 nm. The photograph shown in Fig. 10 is taken under the following conditions: the MCP gain is #5, the film is Polaroid type 107, the writing speed is 2 mm/ μ s, the width of the exit slit of the spectroscope is 1 mm, and the irises of the relay lenses are fully opened. A horizontal line appears at the lower part of the photograph similarly to Fig. 9; the line is broader in Fig. 10 than in Fig. 9 because the slit width is wider.

The brightness of this photograph is compared with that taken by the rotating mirror streak camera combined with the same spectroscope. The results are similar to those mentioned in the last section. To make more exact comparison, the wavelength dependence of sensitivities of both photocathode and film must be investigated.

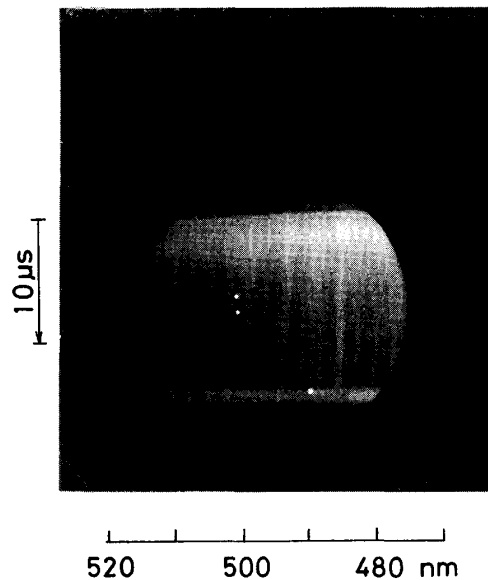

Fig. 10. Spectroscopic streak photograph of xenon-flash.

VI. Conclusion

The present apparatus is found to be more useful as an independent streak camera than as an image intensifier of another streak camera, i.e. the image intensifier tube has to be operated as the streak tube with the deflecting plates. This streak tube camera has higher sensitivity than that of the rotating-mirror streak camera, so the initial aim of this study is nearly achieved. However, there is much room for further improvement. For example, the sensitivity may be greatly enhanced by the use of fiber optics.

The streak tube camera is superior to the rotating mirror camera in easy triggering. Especially, when two photographs are taken by two streak cameras for a single phenomenon, it is impossible to use two rotating-mirror cameras because of the difficulty in triggering. Now, the present authors are making a

research on exploding wires using the streak tube camera and the rotating-mirror camera to take streak photographs of the real object and the luminous spectrum simultaneously. The results will be reported elsewhere.

Acknowledgements

The authors wish to express their cordial thanks to the concerned members of Hamamatsu TV Co., Ltd. for supplying the streak tube. They are also indebted to Mr. H. Moriya for his assistance during the experiment.

A part of the expense of this investigation was supported by the Grant-in-Aid of the Fundamental Scientific Research of the Ministry of Education.