

# Design Guidelines for a Global and Self-Managed LEO Satellites-based Sensor Network

Tarik Taleb<sup>1,\*</sup>, Farid Nait-Abdesselam<sup>2</sup>, Abbas Jamalipour<sup>3</sup>, Kazuo Hashimoto<sup>1</sup>, Nei Kato<sup>1</sup>, and Yoshiaki Nemoto<sup>1</sup>

<sup>1</sup> Graduate School of Information Sciences

Tohoku University, Japan

\*talebtarik@ieee.org

<sup>2</sup> University of Sciences & Technologies of Lille, France

<sup>3</sup> School of Electrical & Information Engineering

University of Sydney, Australia

**Abstract**—This paper describes the architecture of a global sensor network based on a constellation of LEO satellites. The considered sensor network is heterogeneous: Two types of sensor nodes are envisioned. One type does the sensing and relays the gathered data to the other type that performs data aggregation and communicates it directly to the satellites. The main challenging tasks in the design of the architecture are explored and adequate solutions are provided. A set of data dissemination techniques is then presented. Following this, a mathematical model is developed to evaluate the energy use of the sensors. Open research issues for the realization of such architecture are finally discussed.

## I. INTRODUCTION

Along with the on-going advances in low-power electronics and the tremendous need for sensor technology, small and low-cost sensors have emerged in the last few years. The success of a sensor network is heavily dependent on two key resources, namely communication bandwidth and nodes energy. To tackle these two constraints, a large body of pioneering research work has been done. Most of these researches consider the design of sensor networks where sensors are interconnected via a wireless terrestrial network (e.g. terrestrial base stations). Compared to wireless networks, satellite communication systems offer an array of advantages. Effectively, in addition to their inherent multicast capabilities and flexible deployment features, satellite systems are able to provide coverage to extensive geographic areas and interconnect among remote networks. As a consequence, there is an important interest to use satellites in large-scale deployment of sensors.

Among satellite-based sensor networks, the ARGO project is a notable example [1]. In this system, a number of sensors are deployed over the entire ice-free zone of the World's Oceans. They are designed to probe for specific measures related to temperature and salinity. The probing is performed every ten days. Once the requested data is collected, it is then transmitted to the system administrator via a Geostationary (GEO) satellite. In [2], Marchese *et al.* consider also the use of GEO satellites to connect sensor nodes to a number of fixed earth stations. In the considered architecture, sensor nodes collect the required data and transmit it to sink nodes, fixed at earth stations. In turn, the sink nodes send the data to the principal administrator of the system. To propagate information through the entire network and to manage sink nodes, a number of flooding based data delivery techniques is proposed.

While there have been few attempts in using GEO satellites as a part of sensor networks, to the best knowledge of

the authors, no previous research work has considered the integration of Low Earth Orbit (LEO) satellites with sensor networks. LEO systems have been considered as integral parts of a wide range of architectures aiming to provide a plethora of services, ranging from Internet provision to broadband multimedia delivery [3]–[5]. In this paper, we demonstrate that LEO systems can play also an important role in the deployment of an efficient and global sensor network. We discuss issues related to the realization of such network and provide adequate solutions.

The remainder of this paper is organized as follows. Section II showcases some research work related to sensor networks. The key components of the considered architecture are portrayed in Section III. A set of mechanisms for data gathering and transmission are also presented. To evaluate the energy consumption of the entire sensor network, a mathematical model is developed in Section IV. Concluding remarks are given in Section V.

## II. RELATED WORK

As previously mentioned, limited research work has been conducted on the integration of satellites with sensor networks. In light of this lack of research, this section aims to introduce only research works related to sensor networks that formulate the basis of our research work.

Sensor networks can be classified into two categories: homogeneous and heterogeneous. In the former, all nodes are identical. They carry out sensing according to identical procedures. In [6], a homogenous sensor network is considered. The network is divided into a number of clusters. Each cluster has a head that is selected from among the population nodes of the cluster. To guarantee connectivity and coverage over the entire network, mathematical results demonstrated that the number of clusters should scale to the square root of the total number of sensor nodes. As cluster heads collect data from their neighbors, perform data aggregation, and transmit the gathered data directly to distant remote base stations, they exhibit the highest energy drainage rate. For an efficient load balancing among the nodes, a periodic rotation of the cluster head is considered. Another hierarchically clustered homogeneous network is proposed in [7]. In this network, cluster heads are chosen randomly at a given probability. A tradeoff between the system lifetime and the head selection probability is found through a mathematical model.

While a large body of research work considered

homogeneous sensor networks where all the nodes share the same hardware complexity, research directions have been turned towards heterogeneous networks where different types of nodes are utilized; few with high hardware complexity and the majority with less complexity [8], [9]. Low-cost nodes are assumed to merely get data and transmit it to appropriate “complex” sensor nodes. The latter have the highest energy burden as they perform data aggregation and long-range transmissions to distant remote stations. Significant disproportion in the energy drainage over the entire network may thus happen. This yields loss of connectivity and coverage. For a successful design of a heterogeneous network, the system engineer should ensure that all nodes run out of energy at almost the same time. In [9], Mhatre *et al.* developed a mathematical model that minimizes the overall cost of a sensor network, guarantees connectivity and coverage of the sensed field during the lifetime of the network, and ensures a sharp and nearly simultaneous cutoff in the battery of almost all nodes.

In the proposed architecture, we also consider a heterogeneous sensor network. To ensure connectivity and a sharp cutoff effect, we adopt the mathematical model developed in [9]. Unlike most research works, clustering of nodes is dynamic in our approach and is dictated to sensor nodes directly from the satellites. Low-cost nodes join clusters based on prior knowledge on their distance to cluster heads. This information is usually not available in traditional sensor networks, unless a storm of query packets is flooded over the entire network. By knowing distance to their cluster head, nodes can adjust their transmission power, hence an efficient use of nodes energy. Furthermore, unlike most research works where all cluster heads communicate their data to distant base stations, in the proposed approach only one cluster head performs this operation on behalf of the other cluster heads. This significantly minimizes the overall use of nodes energy.

### III. LEO SATELLITES-BASED SENSOR NETWORK

#### A. Key Elements of the Network Architecture

The envisioned deployment architecture consists of the coverage area of a satellite constellation made of  $M$  LEO satellites. The satellites are set in an orbit distant from the earth surface by an altitude  $H$ . A number of sensor nodes are dispersed over the entire network area. Two types of sensor nodes are considered. Ordinary Nodes (ON) are low power, relatively inexpensive, and small-sized sensors. The other type of nodes has complex software and higher hardware. Such nodes are assumed to have enough power to communicate directly with satellites. They act as sink nodes within the network. Indeed, nodes organize themselves into local clusters. Nodes with higher complexity act as heads of each formed cluster. These nodes are dubbed Cluster Heads (CH) throughout this paper.

Ordinary nodes gather the necessary data from the studied field and transmit data directly to their corresponding cluster head. A set of mechanisms will be introduced later in this section on how the clustering procedure is performed. CH

nodes aggregate data from ordinary nodes according to specific signal processing functions and communicate them directly to the system administrator (located in the ground) via the satellites. For communication among sensor nodes, two modes can be envisioned: single hop and multi-hop. In the former, a direct communication path is established between two sensor nodes. In this mode, nodes located far away from sink nodes have high-energy burden due to long communication range. A possible solution to this issue is to form clusters of small size. In the multi-hop, as its name infers, communication goes through a number of nodes. One drawback of this mode is that nodes closer to sink nodes have to deal with an excessive number of relaying packets, a fact that may put their connectivity in danger. As analytical comparison between the two modes is outside the scope of our study, interested readers are referred to [10]. To investigate which mode is better suited for heterogeneous or homogeneous networks, [11] may be also a good reference. For the sake of analysis simplicity, we adopt the single-hop mode in our developed mathematical model.

#### B. Problem Formulation

To deploy the above-mentioned sensor network, a number of issues should be addressed. First, given the heterogeneity of the designed system, ordinary nodes should be able to select the most optimum CH node to communicate their data to. In other words, in the presence of multiple CH nodes over a given geographical area, clustering of sensor nodes should be made in the most adequate way to guarantee an efficient use of the network energy. Second, in light of the frequent occurrences of handovers in LEO satellite networks, such phenomenon should be taken into account in the design of the communication protocols so as that the least effect of handovers on the overall system performance can be guaranteed. Third, as CH nodes are assumed to communicate the aggregated data to satellites, a fact that intrigues a high use of energy given the altitude of satellites, it would be more beneficial if a single CH node handles such operation on behalf of the others. An efficient election of such node is thus required. Additionally, as some areas on the Earth surface can be covered by more than one satellite in LEO constellations, issues related to this coverage diversity should be also addressed during the election of the node to communicate data to satellites. In the remainder of this section, we attempt to find solutions to the above raised issues.

#### C. Communication Techniques

During the set-up phase of the sensor network, nodes should be deployed over the coverage space of the constellation in a manner that guarantees efficient wide-area connectivity during the entire lifetime of the network. To achieve this objective, the number of CH nodes ( $N_1$ ) should ideally scale to the square root of the total number of nodes ( $N$ ), as demonstrated in [9]. During the deployment phase, the system designer should also take into account the predefined specifications (e.g. geological structure) and requirements (e.g. sensing accuracy, latency) of each region to be sensed. Additionally, to ensure that all nodes

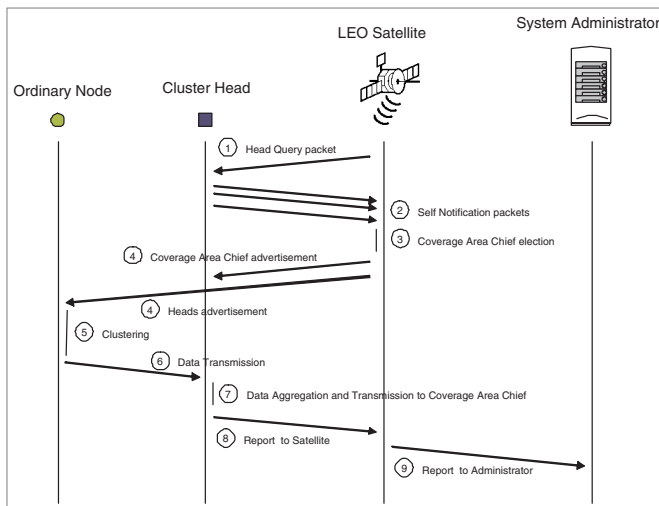

Fig. 1. Major steps in data gathering cycle.

Node ID	Geographical Location	Battery Level	Chief Election History	Flag	Option
---------	-----------------------	---------------	------------------------	------	--------

Fig. 2. Format of a Self-Notification packet.

start up functioning at the same time, the system administrator can request all satellites to broadcast synchronization pulses to all nodes at the set-up phase of the system.

The operation of the system is divided into a number of data gathering cycles. The lifetime of the system is intuitively defined as the total number of these rounds until a sharp cutoff occurs in the activity of the nodes. Fig. 1 depicts the major steps in each data gathering cycle. Each round is conducted as follows:

- Step 1: At the beginning of each cycle, satellites broadcast a Head Query (HQ) packet to CH nodes within their coverage areas. As the name infers, this packet aims to seek available CH nodes within the coverage area of each satellite.
- Step 2: In response to Head Query packets, CH nodes transmit a Self-Notification (SN) packet to the asking satellites. Fig. 2 shows a typical format of a Self-Notification packet. The packet consists of six fields. In addition to the identifier (ID) of the node, it contains information on the node's geographical location and its current energy level. The Chief Election History field indicates the last time the node was elected as a Coverage Area Chief (CAC – to be explained in the next step). The node sets the flag field to one if it resides in the overlapping area of the coverage areas of different satellites. The option field is for additional use.
- Step 3: At this step, using metrics available at SN packets, satellites choose representatives for their coverage areas, dubbed as Coverage Area Chiefs (CACs) throughout this paper. CACs are assumed to gather data from ordinary nodes that are under their commands and also from heads of clusters that are within their coverage areas. Selection of coverage area chiefs can be based on different attributes. First, not to give too much burden to CH nodes and to avoid handover related issues,

heads that are within the overlapping area of multiple coverage areas are exempted from the CAC job. If at a given satellite coverage area, all heads reside in the overlapping area with other coverage areas, a scenario that is unlikely to happen provided an intelligent initial distribution of the CH nodes, the satellite should then consider electing such heads (with flag set to one) for the CAC duty. Second, as the energy consumption is proportional to distance, satellites should select heads that are geometrically closest to them. This can be achieved by referring to the information on the geographical location of the heads available at the SN packets. Intuitively, this operation would minimize the energy drainage of the chosen CAC nodes. Furthermore, to guarantee a fair rotation of the CAC job among heads and to accordingly avoid draining the battery of some at the price of saving the battery of others, satellites should refer to the Chief Election History and the energy level of the nodes. Intuitively, nodes that are named as chiefs less frequently and have more energy should be selected as CAC. Given the fact that several metrics are involved in the election of a CAC, satellites can adopt a Multi-Attribute Decision Making (MADM) approach to select the most optimum head to represent their coverage areas [12].

- Step 4: Having decided a representative for each satellite coverage area, satellites broadcast two types of advertisement packets: CAC Advertisement packet and Heads Advertisement packet. The former is destined for CH nodes. It informs them of the current CAC. In contrast, Heads Advertisement packets are sent to ordinary nodes informing them of a list of available heads within the satellite coverage area and their geographical locations.
- Step 5: At this stage, ordinary nodes perform clustering using geographical information available at Heads Advertisement packets. Once again, to guarantee minimum communication energy, ordinary nodes select heads that are closest to them. For nodes that are in the overlapping area of multiple connections and that may be interested in communicating with heads residing in other coverage areas than their corresponding one, satellites should add information on heads that are available at the coverage areas of their neighboring satellites in the Heads Advertisement packets. This operation would slightly increase the length of the Heads Advertisement packets. By knowing distance to their selected heads, ordinary nodes can use their power control to adjust the transmission power. This will significantly help to avoid energy dissipation, mainly in case of a single-hop mode. Concerning load balancing, admittedly some heads may have to deal with relatively large number of ordinary nodes while others deal with few of them. This will yield to uneven and non-uniform energy drainage among CH nodes. However, this will ultimately be reflected in the energy level of the head. Affected CH nodes will be accordingly exempted from the CAC job for a

number of rounds. Recall that significantly higher energy is required to transmit data to a far point (e.g. satellite) than receiving data from a nearby node. Consequently, being exempted from the CAC job may be sometimes worthier than receiving a bunch of packets from a number of neighboring nodes. Furthermore, it should be emphasized that while it is possible for nodes, within a given coverage area, to communicate their data directly to the designated CAC, this incurs further overhead in terms of the hardware complexity that should be adhered to ordinary nodes. In this context, clustering is efficient in improving power control, system capacity, and resource utilization.

- Step 6: Once the sensing data is collected and the nodes determine their cluster heads, they transmit this data to the selected head. For this purpose, different routing protocols can be considered [13]. The nodes can use also a wide library of MAC protocols for data transmission, such as TDMA, FDMA, and CSMA [14].
- Step 7: At this stage, cluster heads, including CAC, enter the steady state phase where they carry out data aggregation. They then transmit the aggregated data to the Coverage Area Chief; obviously apart of the latter that performs data aggregation and has to wait for a while till it receives data from all other cluster heads within its coverage area. Knowing the geographical location of each cluster head, information that is available at the CAC Advertisement packet, the CAC can set up a wait timeout as an estimate of the time required for heads to collect data from nodes under their command, carry out data aggregation, and transmit data to the CAC.
- Step 8: Once the CAC receives data from all heads or the timeout expires, the CAC performs again data aggregation to further enhance the quality of the signal by reducing the uncorrelated noise among signals and proceeds with transmitting all data in the format of a Report packet to the corresponding satellite.
- Step 9: As the satellite receives the Report packet, it transmits it to the system administrator. The administrator carries out analysis to determine characteristics of the environment or to detect an event according to the system requirements and goals.

#### IV. ENERGY EFFICIENCY

In this section, we develop a simple mathematical model to determine the required battery energy of nodes during each round of the data gathering procedure. The used notations are listed in Table I. In the remainder of this paper, we use ( $i = 0$ ) and ( $i = 1$ ) to index ordinary nodes and cluster heads, respectively.

First, the surface of the coverage area of a single satellite can be computed as follows.

$$S_{CA} = \pi \left( \frac{H}{\tan(\alpha)} \right)^2 \quad (1)$$

TABLE I  
USED NOTATIONS.

Parameters	Notation
Number of satellites in constellation	$M$
Satellite Altitude	$H$
Minimum Elevation Angle	$\alpha$
Total number of sensor nodes	$N$ ( $N_i$ nodes of type $i$ )
Type $i$ node distribution	$\rho_i(x, y)$
Initial battery energy of type $i$ node	$B_i$

Assuming that type  $i$  nodes are distributed over the entire network with a node distribution  $\rho_i(x, y)$ , the total number of type  $i$  nodes in the coverage area of a single satellite can be expressed as follows.

$$\begin{aligned} N_i^{CA} &= \int \int \rho_i(x, y) dx dy \\ &= \int_{\theta=0}^{2\pi} \int_{r=0}^{\frac{H}{\tan(\alpha)}} \rho_i(r, \theta) dr d\theta \end{aligned} \quad (2)$$

To compute the energy, we use the energy model as in [6]. To transmit a packet of length  $l$  (in bits) over a distance  $d$ ,  $E_t(l, d)$  energy is required.

$$E_t(l, d) = l \cdot E + \mu \cdot d^2 \quad (3)$$

And to receive a similar packet, the required energy  $E_r(l)$  is

$$E_r(l) = l \cdot E \quad (4)$$

where the electronic energy  $E$  and the amplifier energy  $\mu$  are two constants that depend on the hardware of the nodes. It should be noted that given the wide coverage area of the satellite, and thus, the expected long distance among the nodes, the multi-path fading channels are not considered in the energy model [15].

To compute the energy dissipated in a single coverage area during one round, we denote the length of signaling packets as shown in Table II.

TABLE II  
LENGTH OF EACH PACKET TYPE.

Packet type	Length
Head Query	$l_Q$
Self-Notification	$l_{SN}$
CAC Advertisement	$l_{CAC}$
Heads Advertisement	$l_{HA}$
Report to Heads	$l_{R2H}$
Report to CAC	$l_{R2CAC}$
Report to Satellite	$l_{R2Sat}$

As far as CH nodes are concerned, each of them receives a Head Query packet, sends a Self-Notification packet, and receives a CAC advertisement packet. They all receive  $N_0^{CA}$  Report packets from all ordinary nodes. At this stage the total used energy is

$$E_{1.1} = [N_1^{CA}(l_Q + l_{SN} + l_{CAC}) + N_0^{CA}l_{R2H}] \cdot E + N_1^{CA} \mu d_{Sat2H}^2 \quad (5)$$

where  $d_{Sat2H}$  denotes the distance of the satellite to the CH nodes. Using the distribution function of the CH nodes and the Pythagoras' theorem, the expected squared distance of the

satellite to a given CH node can be computed as

$$\begin{aligned} d_{Sat2H}^2 &= H^2 + \int \int (x^2 + y^2) \rho_1(x, y) dx dy \\ &= H^2 + \int_{\theta=0}^{2\pi} \int_{r=0}^{\frac{H}{\tan(\alpha)}} r^3 \rho_1(r, \theta) dr d\theta \end{aligned} \quad (6)$$

In the next level,  $(N_1^{CA} - 1)$  CH nodes perform data aggregation and send their reports to the chosen CAC. The used energy at this level can be expressed as follows

$$E_{1.2} = (1 - p_{CAC})(N_1^{CA} - 1) [l_{R2CAC} E + \mu d_{H2CAC}^2 + E_{CH}^{aggr}] \quad (7)$$

where  $(p_{CAC} = 1/N_1^{CA})$  denotes the probability of a cluster head to be elected as CAC and  $E_{CH}^{aggr}$  refers to the average energy required by cluster heads for data aggregation.  $d_{H2CAC}$  is the distance between a cluster head and the selected CAC. As all cluster heads are arbitrarily dispersed over the coverage area with a node distribution  $\rho_1(x, y)$ , the expected squared distance from a cluster head to the selected CAC can be formulated as

$$\begin{aligned} d_{H2CAC}^2 &= \int \int (x^2 + y^2) \rho_1(x, y) dx dy \\ &= \int_{\theta=0}^{2\pi} \int_{r=0}^{\frac{H}{\tan(\alpha)}} r^3 \rho_1(r, \theta) dr d\theta \end{aligned} \quad (8)$$

After receiving report packets from other cluster heads, the selected CAC carries out again data aggregation and reports the data to the satellite. The required energy is

$$E_{1.3} = p_{CAC} [(N_1^{CA} - 1) l_{R2CAC} + l_{R2Sat}] E + \mu d_{CAC2Sat}^2 + E_{CAC}^{aggr} \quad (9)$$

where  $E_{CAC}^{aggr}$  and  $d_{CAC2Sat}$  denote the energy required by the CAC for data aggregation and its distance to the satellite, respectively. Remark that the expected squared distance of the CAC node to the satellite ( $d_{CAC2Sat}^2$ ) is equal to the expected squared distance of the satellite to any CH node  $d_{Sat2H}^2$  (Equation 6),  $E_{1.3}$  can be easily derived. Adding the three energies, the total energy required by CH nodes during each round is

$$E_1 = E_{1.1} + E_{1.2} + E_{1.3} \quad (10)$$

Concerning ordinary sensor nodes, they receive Heads Advertisement packets from the satellite and have to report their data to their selected heads. For nodes residing in the overlapping area of multiple satellites, they may receive multiple Heads Advertisement packets. While this scenario may slightly affect the overall consumption of the nodes energy, we omit it from our mathematical analysis for the sake of analysis simplicity. The required energy by ordinary nodes can be thus expressed as follows

$$E_0 = N_0^{CA} [(l_{HA} + l_{R2H}) E + \int \int d_{N2H}^2 dx dy] \quad (11)$$

where  $d_{N2H}$  is the distance between an ordinary node and a cluster head.

To compute the squared distance from an ordinary node to a cluster head, we assume that cluster heads control areas of equal surfaces. The surface of these areas can be approximately expressed as follows

$$S_{CH} = \frac{S_{CA}}{N_1^{CA}} \quad (12)$$

To further simplify the equations, we assume that these areas are circles with radius

$$R_{CH} = \sqrt{\frac{S_{CA}}{\pi N_1^{CA}}} \quad (13)$$

The required energy of ordinary sensor nodes can be then formulated as

$$E_0 = N_0^{CA} [(l_{HA} + l_{R2H}) E + \int_0^{2\pi} \int_0^{R_{CH}} r^3 \rho_0(r, \theta) dr d\theta] \quad (14)$$

Using the above model, we can approximately compute the lifetime of the entire network. Indeed, knowing the initial energy of the nodes, the lifetime of the entire network, in terms of the number of rounds, can be expressed as

$$\text{Min} \left( \text{Avg} \left( \frac{N_1^{CA} B_1}{E_1} \right), \text{Avg} \left( \frac{N_0^{CA} B_0}{E_0} \right) \right) \quad (15)$$

Obviously, in order to guarantee a sharp cutoff over the entire network, and thus avoid the waste of nodes energy, the factor  $\text{Avg} \left( \frac{N_1^{CA} B_1}{E_1} - \frac{N_0^{CA} B_0}{E_0} \right)$  should be maintained in the vicinity of zero.

To illustrate the idea at hand, we consider the following example values. The satellite altitude and the minimum elevation angle of the constellation are set to  $10000 \text{ Km}$  and  $\frac{\pi}{6}$ , respectively. For the sake of simplicity, the node distributions of both ordinary nodes and cluster nodes are assumed to be uniform and independent of geographical location. The lengths of signaling packets are set to appropriate values based on the information they are supposed to provide as shown in Table III. The length of some packets is proportional to the number of cluster heads ( $N_1^{CA}$ ) or the number of ordinary nodes ( $N_0^{CA}$ ) in a given coverage area. In the setting of packet lengths, we ignore the data aggregation procedure. The average energy required by cluster heads and CAC for data aggregation is thus set to null ( $E_{CAC}^{aggr} = E_{CH}^{aggr} = 0$ ). Similarly to [6], the electronic energy  $E$  and the amplifier energy  $\mu$  are set to  $50 \text{ nJ/bit}$  and  $10 \text{ pJ/bit/m}^2$ , respectively. It should be emphasized that the aforementioned values are chosen with no specific purpose in mind and shall not change any of the fundamental observations about the system.

To ensure a sharp cutoff in the energy of sensor nodes, the following equation should hold:

$$\frac{N_1^{CA} B_1}{E_1} = \frac{N_0^{CA} B_0}{E_0} \Rightarrow \frac{B_1}{B_0} = \frac{N_0^{CA} E_1}{N_1^{CA} E_0} \quad \forall CA \quad (16)$$

To investigate the correlation between the distributions of the two node types and their initial battery energy when a sharp

TABLE III  
LENGTH OF EACH PACKET TYPE.

Packet type	Length (bits)
Head Query	5
Self-Notification	15
CAC Advertisement	9
Heads Advertisement	$N_1^{CA} \cdot 9$
Report to Heads	5
Report to CAC	$\frac{5 \cdot N_0^{CA}}{N_1^{CA}} + 3$
Report to Satellite	$N_0^{CA} \cdot +3$

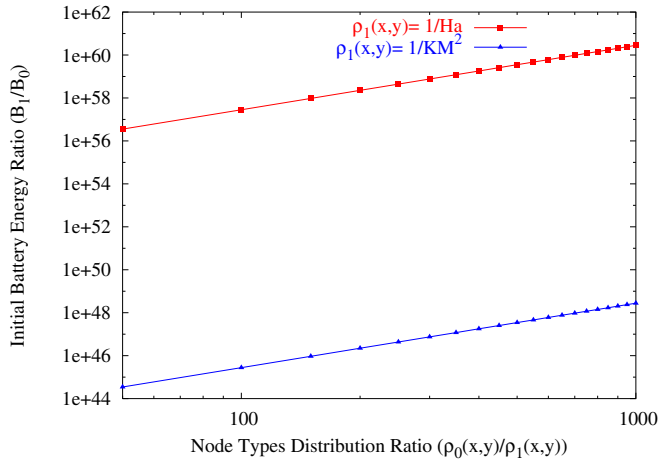

Fig. 3. Correlation between node types distribution and their initial battery energy to ensure a sharp cutoff in the battery of all nodes.

cutoff in the sensor nodes energy is guaranteed, we plot the ratio of the nodes initial battery energy ( $\frac{B_1}{B_0}$ ) in function of the ratio of the nodes distribution ( $\frac{\rho_0(x,y)}{\rho_1(x,y)}$ ) in Fig. 3. We envision two cases by setting the cluster heads distribution to two values,  $\frac{1}{Ha}$  and  $\frac{1}{Km^2}$ . Fig.3 indicates an interesting observation. It shows that the logarithms of the two metrics are linearly proportional to each other.

$$\log\left(\frac{B_1}{B_0}\right) = \gamma \log\left(\frac{\rho_0(x,y)}{\rho_1(x,y)}\right) \Rightarrow \frac{B_1}{B_0} = \left(\frac{\rho_0(x,y)}{\rho_1(x,y)}\right)^\gamma \quad (17)$$

This result is highly important for the sensor network designer to estimate the total cost of the system. Indeed, knowing the number of nodes to be deployed and the distribution of each type, the network designer can decide the initial battery of each node type, thus the hardware cost of each node and ultimately the cost of the whole system, to ensure a sharp cutoff in the entire system energy.

## V. CONCLUSION

In this paper, we considered the use of LEO satellites to build a global and energy-efficient sensor network. To reduce the total cost of the architecture, a heterogeneous environment with two types of nodes is envisioned. Exploiting the multicast capabilities of the satellites, a set of signaling packets are introduced to guarantee an efficient use of the nodes energy. Nodes are grouped into dynamically changing clusters based on their distance to cluster heads. Their transmission powers are accordingly adjusted. This directionality-based transmission fashion helps to largely minimize the energy

drainage at each node. At each coverage area, a single cluster head gathers data from its neighboring cluster heads and transmits it to the satellite on behalf of them. This yields to an efficient use of the cluster heads energy. From these characteristics, the proposed approach is expected to achieve significant savings in the scarce energy of nodes and thus to increase the lifetime of the sensor network. A mathematical model is developed to evaluate the energy use of the whole system during each process round. The developed model helps to estimate the lifetime of the whole system given the initial battery of the nodes. It can be used also to put constraints on the hardware specifications of the nodes to guarantee a sharp cutoff in the battery of all nodes.

Finally, it should be noted that while we have considered only LEO satellites in the proposed architecture, our study can be easily extended to the case of GEO systems. In such network, given the extensive coverage area of GEO satellites and their high altitude, significant transmission power will be required at cluster heads and the entire system cost may be affected. More cost-effective systems can be considered by substituting LEO systems with High-Altitude Platforms (HAP) or Unmanned Airborne Vehicles (UAV).

## REFERENCES

- [1] URL <http://www.argo.ucsd.edu>
- [2] M. Marchese et al., "Information Distribution Techniques in Sensor Networks via Satellite", in Proc. of ICC 2006, Istanbul, Turkey, Jun. 2006.
- [3] T. Taleb, N. Kato, and Y. Nemoto, "On-Demand Media Streaming to Hybrid Wired/Wireless Networks over Quasi-GEO Stationary Satellite Systems", Elsevier J. Computer Networks, Vol. 47, No. 2, Feb. 2005. pp 287-306
- [4] T. Taleb, N. Kato, and Y. Nemoto, "Recent Trends in IP/NGEO Satellite Communication Systems: Transport, Routing, and Mobility Management", IEEE Wireless Communications Magazine, Oct. 2005, pp. 63-69.
- [5] T. Taleb, N. Kato, and Y. Nemoto, "REFWA: An Efficient and Fair Congestion Control Scheme for LEO Satellite Networks", IEEE/ACM Transactions on Networking Journal, Oct. 2006. (to appear)
- [6] W.B. Heinzelman, A.P. Chandrakasan, and H. Balakrishnan, "An Application-Specific Protocol Architecture for Wireless Microsensor Networks", IEEE Trans. Wireless Commun., Vol. 1, No. 4, Oct. 2002.
- [7] S. Bandyopadhyaya and E.J. Coyle, "An Energy Efficient Hierarchical Clustering Algorithm for Wireless Sensor Networks", in Proc. IEEE Infocom 2005, San Francisco, CA, USA.
- [8] G. Gupta and M. Younis, "Fault-Tolerant Clustering of Wireless Sensor Networks", In Proc. IEEE Wireless Commun. & Networking Conf. (WCNC), Mar. 2003, New Orleans, LO, USA.
- [9] V. Mhatre et al., "A Minimum Cost Heterogeneous Sensor Network with a Lifetime Constraint", IEEE Trans. Mobile Computing, Vol. 3, No. 3, Jul/Sep 2004.
- [10] V. Mhatre and C. Rosenberg, "Design Guidelines for Wireless Sensor Networks: Communication, Clustering, and Aggregation", Elsevier J. Ad Hoc Networks, Vol. 2, 2004. pp. 45-63
- [11] V. Mhatre and C. Rosenberg, "Homogeneous vs Heterogeneous Networks: A Comparative Study", In Proc. ICC 2004, Paris, France.
- [12] R.L. Keney and H. Raiffa, "Decisions with Multiple Objectives: Preferences and Value Trade-offs", Wiley, Cambridge Univ. Press, 1993.
- [13] K. Akkaya and M. Younis, "A survey on routing protocols for wireless sensor networks", Elsevier Journal on Ad Hoc Networks, Vol. 3, No. 3, May, 2005.
- [14] I.F. Akyildiz et al., "Wireless Sensor Networks: A Survey", Elsevier J. Computer Networks, Vol. 38, 2002. pp. 393-422
- [15] T. Rappaport, "Wireless Communications: Principles and Practice", Englewood Cliffs, Prentice Hall, 1996.